

## LTVCHV 40

### Description:

This cylindrical vessel is installed on three adjustable feet, with efficient capacity of 4 000 l. This vessel is designed for final fermentation, storage and racking of beer.

### Accessories:

|   |        |
|---|--------|
| Oval manhole 340*420 mm                       | 1.4301 |
| Sanitary rotating shower with piping DN 32 mm | 1.4301 |
| Underpressure/overpressure armature DN 25     | 1.4301 |
| Supply and discharge flap valve DN 32         | 1.4301 |
| Upstream armature DN 32                       | 1.4301 |
| Blind flange DN 32, 1 piece                   | 1.4301 |

### Parameters

|                  |          |
|------------------|----------|
| Overall height   | 2 890 mm |
| Diameter         | 1 450 mm |
| Overall capacity | 4 235 l  |
| Empty weight     | 394 kg   |

### Warranty:

|                   |           |
|-------------------|-----------|
| LT tank           | 36 months |
| Upstream armature | 36 months |

### Transport

This tank is usually shipped in horizontal position, fixed on special framing. Ground-plan frame dimensions: 2500\*1400 mm.

### DOUBLE-ACTING VALVE

This double-acting valve can be installed in any position, however, it is mounted usually in a vertical position on a vessel top part, screwed in its threaded counterpart on the vessel, under use of proper thread type seal, usually with Teflon packing strips.

1. Body
2. Tube
3. Plate
4. Underpressure plate
5. Food seal EPDM
6. Bolt M6
7. Nut M6
8. Overpressure spring
9. Underpressure spring
10. Adjusting bolt
11. Locking washer

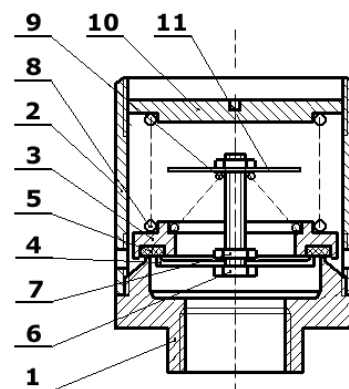

**Scheme**

